

H6G CLAUS REACTOR REFRACTORY DRILLING SYSTEM

FOR 4" TO 6", 90 TO 175mm FLANGED NOZZLE SIZES

PRODUCES THE REQUIRED ENTRANCE HOLE FOR THE HTP THERMOCOUPLE

- New Installations Should be Equipped With ANSI 6" (DIN 150mm) Size Mounting Nozzle
- Existing Nozzles as Small as ANSI 2" (DIN 50mm) Can be accommodated
- Use of the H6G Produces the Required Straight Hole on the Centerline of the HTP Mounting Nozzle.
- The HRS Refractory Stop is Used as Part of the H6G Drilling System
- Available For Immediate Shipment

APPLICATIONS

The Delta Controls H6G guide drill bit assembly is used to drill straight, on the centerline holes, through Claus thermal reactor refractory linings. The H6G guide is rigidly mounted on the vessel nozzle flange and works to keep the core drill bit concentric with and on the centerline of the nozzle while the well hole is being drilled through the refractory liner. The final result is a straight hole that is properly positioned to accept the refractory well and the HTP thermocouple.

This correct hole allows the refractory protective well to be inserted into the reactor and to automatically be in its proper position. The HTP thermocouple can then be mounted on the nozzle flange with assurance that its element protective well is correctly positioned on the centerline of the refractory protective well. This proper positioning protects the HTP from breakage by allowing the refractory to move in relation to the vessel shell without jamming the element well into the refractory well and breaking it off.

Note that hand held positioning of a core drill bit during drilling is unacceptable and will not produce a hole usable for the HTP thermocouple.

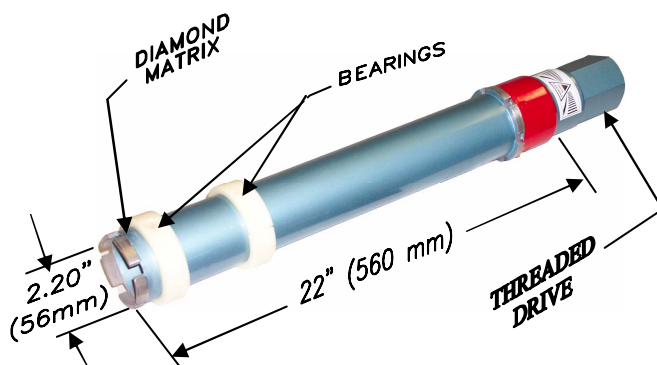

DB1 DRILL BIT



Hole Being Drilled Through Refractory In a Claus Thermal Reactor

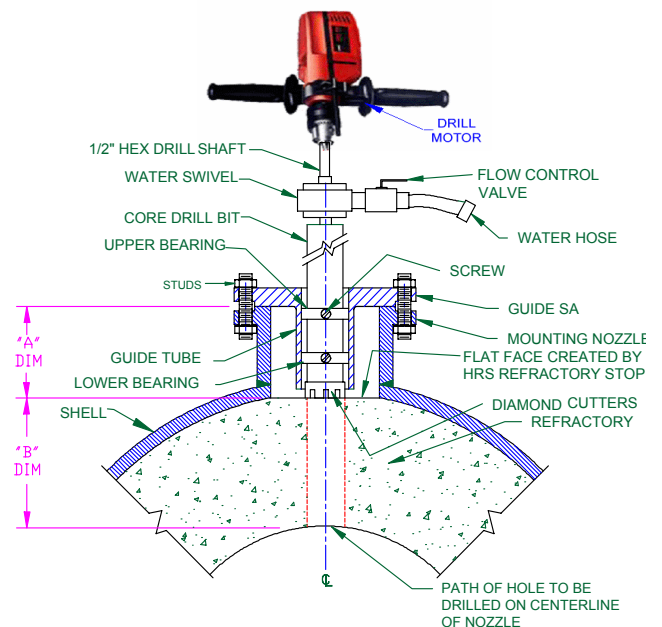

GUIDE AND DRILL BIT IN PLACE.
READY TO PRODUCE A HOLE

SPECIFICATIONS

- Flange Size:** ANSI 4" 150 to 6" 300
DIN 90 To 175 mm
- Nozzle ID:** 3.44" (87mm) and Larger
- Nozzle Height + Refractory Thickness:** Up to 22 inches(560mm) basic: add extension if longer
- Refractory Thickness:** Up to 22" (560mm)
- Hole Size:** 2.20 Inches (56 mm)
- Drill Bit:** Diamond core type, uses water flushing
- Water Swivel:** Bronze bearings, rubber seals, flow control valve, 1/2" hex drill drive shaft; 3' hose
- Drill Motor:** 1/2" chuck size,, 50 to 600 RPM variable speed required
- Option:**
 - (1) Water hose extension: 50 Foot (15 M)
 - (2) Drill bit extension, length as required
12"(300mm), 24" (600mm), or longer.

HOLE DRILLING PROCEDURE

- Start by putting the HRS refractory stop in place before the refractory is installed. This will provide a flat face located at the bottom of the mounting nozzle.
- After the refractory has set, remove the HRS refractory Stop and install the H6G drill guide body on the mounting flange face.
- Assemble the drill bit, water swivel, and drill motor.
- Put the drill bit down into the guide and connect the water hose.
- Ease the bit down against the refractory face and open the water flow control valve.
- Hold or clamp the drill motor securely to prevent injury and drill thru the refractory.
- Inspect the hole to verify the result.

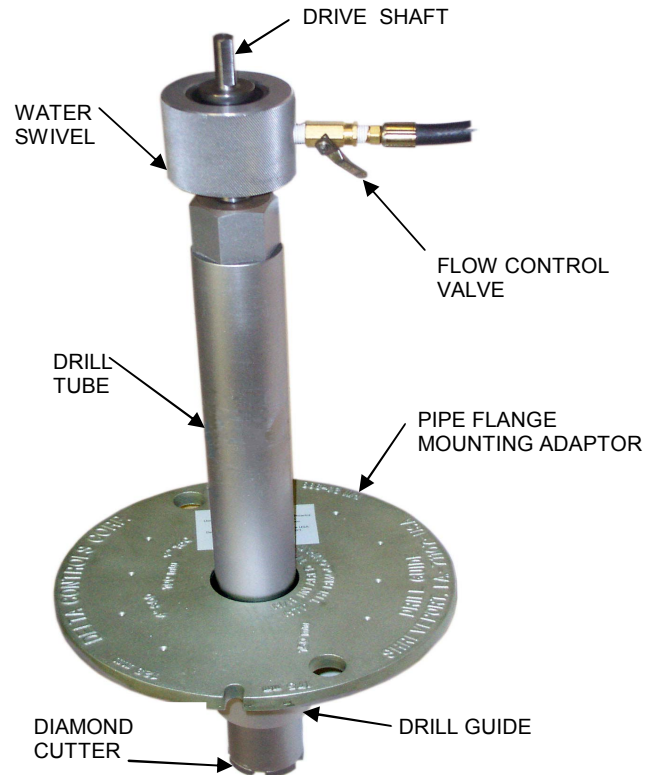

MODEL NUMBERING SYSTEM

BASIC TYPE	NOZZLE I.D.	NOZZLE HEIGHT	REFRACTORY THICKNESS	OPTIONS
MODEL				
EXAMPLE H6G	- 4.0	- 6.5"	- 10.0"	- AA

M/N	DESCRIPTION
*IN	INCHES
*mm	MILLIMETERS
* REPLACE * WITH ACTUAL DIMENSIONS	

M/N	DESCRIPTION
AA	NONE
EX1	12" EXTENSION
WH	50ft (15M) EXTENSION HOSE
DM	1/2" 0-600 RPM; 120VAC 900 WATT; MILWAUKEE #1001-1 DRILL MOTOR

CUTTING ACTION OF THE RB1 REFRACTORY DRILL BIT

Diamond cutting fragments are embedded in a ceramometallic matrix. As the diamonds cut and as the hole progresses, the matrix wears away. Dull diamonds tear away and expose new sharp edged diamonds. The torn off diamonds are then mixed in with the refractory cuttings. The cuttings, with still hard diamonds, must be flushed away with water as they form. Flushing promotes rapid cutting, and straight drilling. Water also cools the bit and lengthens its life.

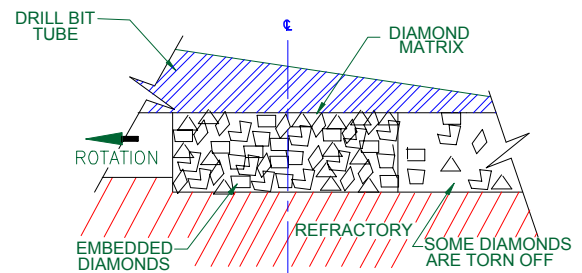

DELTA CONTROLS CORPORATION
 Engineered Sensors – For Difficult Services
 585 Fortson Street
 Shreveport, La. 71107 - USA



Ph: +1(318) 424 8471
 Fx: +1(318) 425 2421
 E-mail: sales@deltacnt.com
 Web: www.claustemp.com